



SOFTWARE COMPONENTS IN OPENOFFICE.ORG

Kay Ramme

Sr. Technical Architect
Sun Microsystems



OpenOffice.org

<http://www.openoffice.org>



- Open Source Office Suite
- ~ 1.5 million downloads a week
- ~ 800.000 daily unique visitors
- ~100 localizations
- ~ 7 million LOC (98% C++)
- ~ 120 million installations
- 10 platforms
- 8 machine architectures
- Various C++ Compilers

Architectural Challenges

- Huge code base
- Monolithic architecture
- Different programming languages
- Big problems because of C++ / C++ ABI
- Accidental incompatible changes

Required: Stable API for 3rd party developers

Architecture

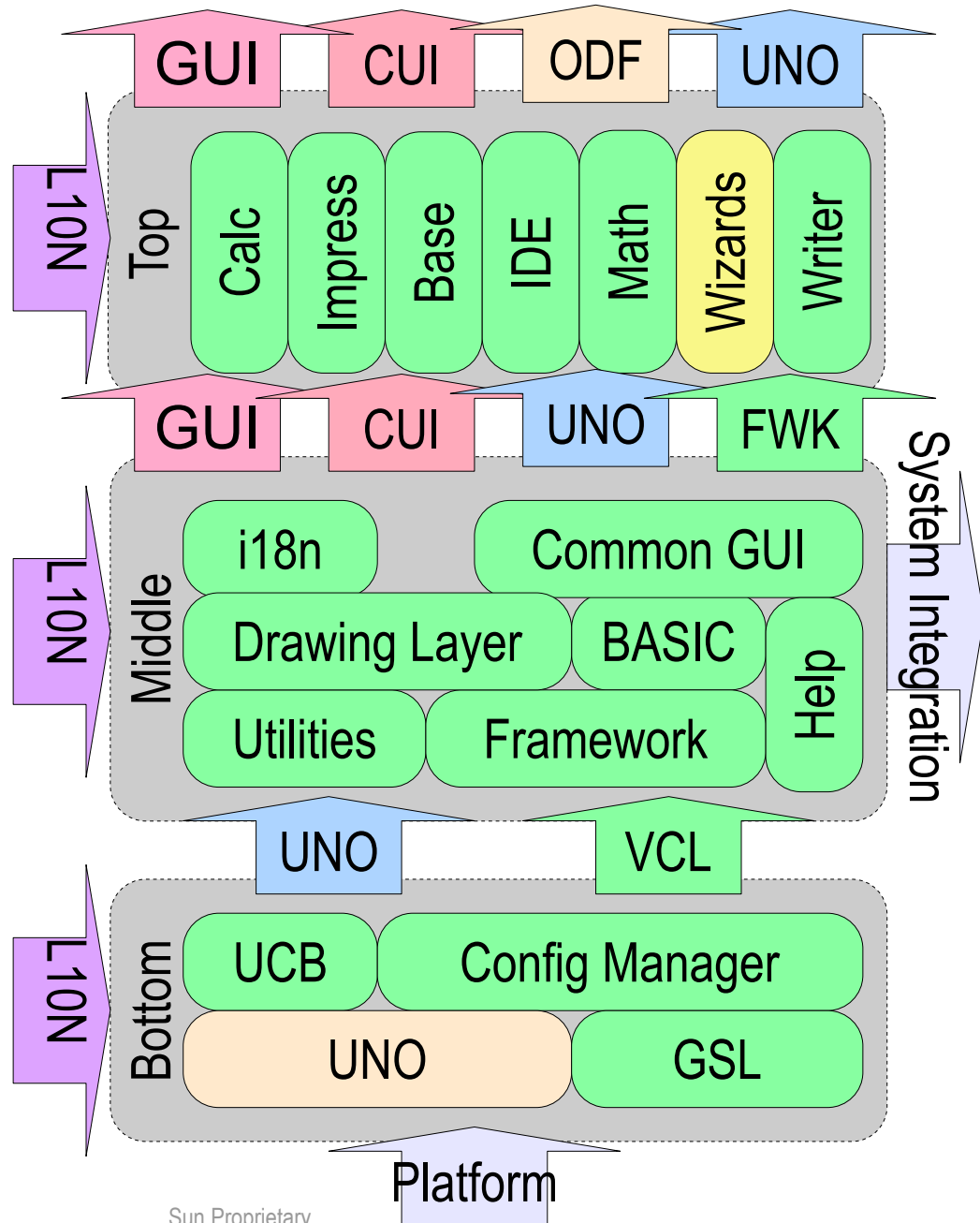

Solution: Divide (into Software Components) and Conquer

Component Architecture

- Have a component model API&ABI only (rest described e.g. by IDL)
- Create a program out of components only
- Recursively refine the architecture

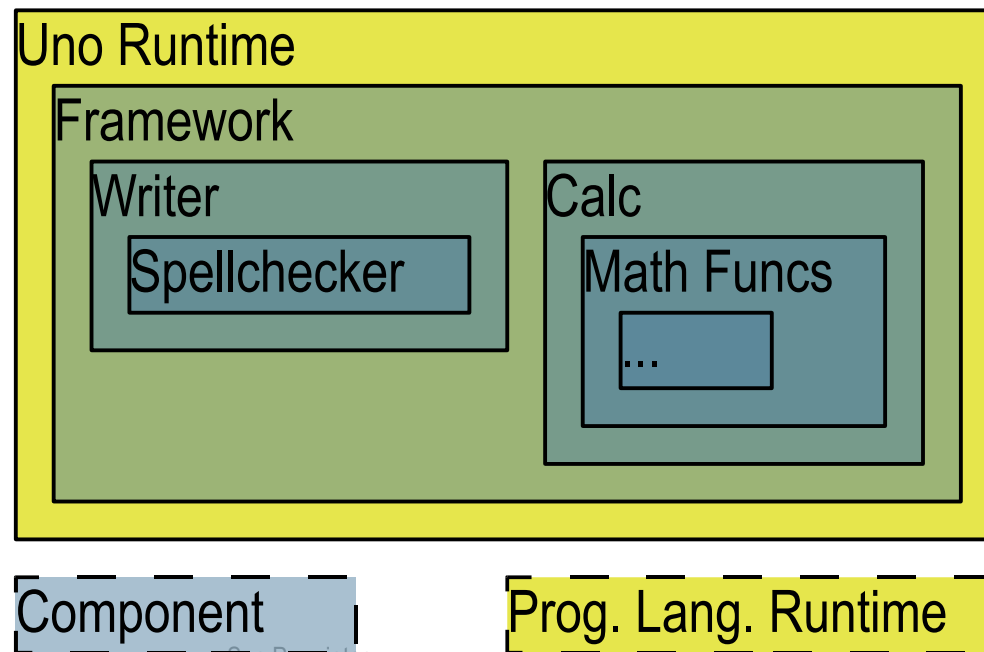

Current Flavors of Components

<http://extensions.services.openoffice.org>

- 3rd Party Functionality
- Input/Output (UCB)
- Filters
- Remote Communication
- Mathematical Functions
- BASIC Libraries
- Uno Services
- New Chart Types
- Spellcheckers
- Templates
- Cliparts
- System Integration

New stuff developed as components

3rd Party components are mostly Java

Universal Network Objects (I)

<http://udk.openoffice.org>

- IDL based
- Exceptions
- Multi threaded
- Multiple inheritance
- No overhead in case of co-location
- Interoperable between various programming languages
- In process / over process, machine boundaries -> remote transparent

Universal Network Objects (II)

- Independent (standalone usable)
- Cross Platform
- Extensible
 - > Bridges
 - > Services
 - > Interfaces
- Uses / supports components
- Unicode based

Reported to be fast :-)

Uno Architecture

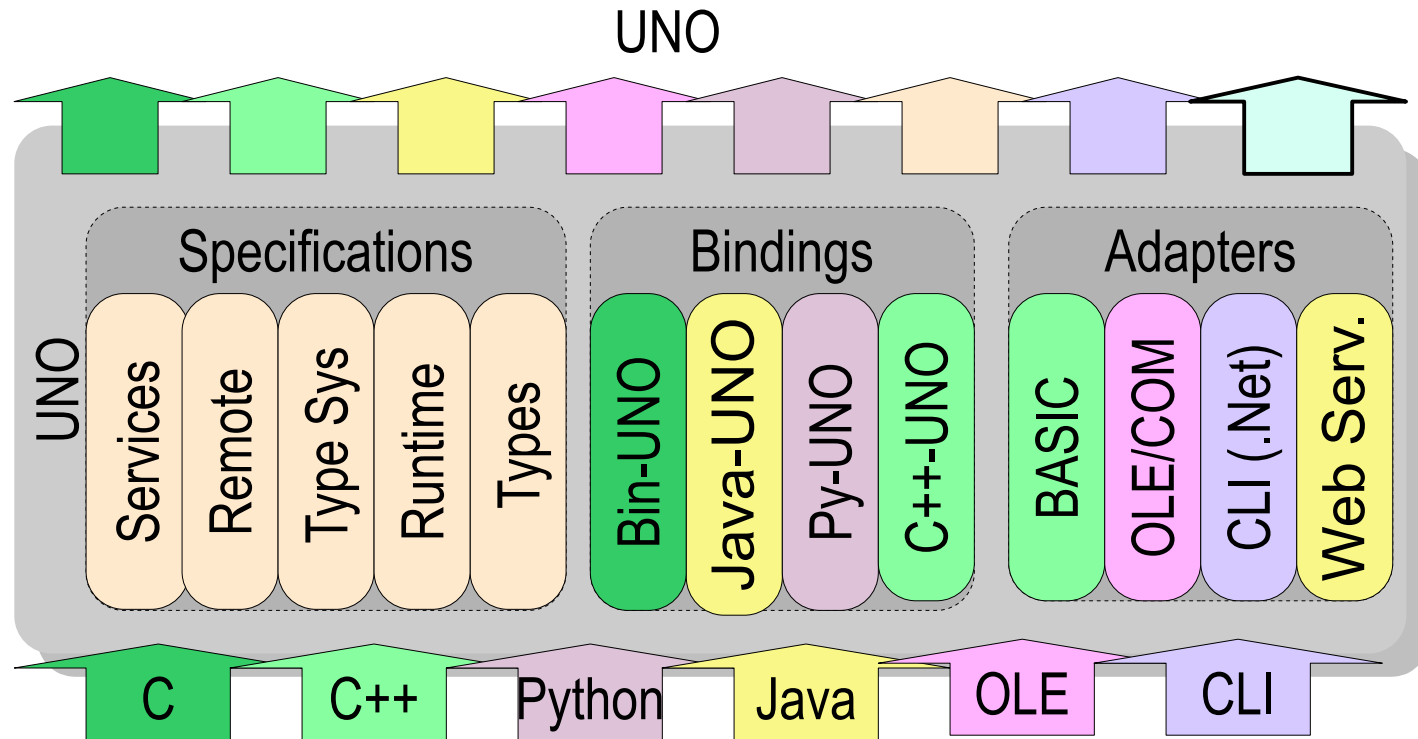

Component Problems

- Different semantics of competing components
- Semantic changes
- Interface Inflation
- Who owns the process?
- Who owns an object?
- Bypassing
- Deployment: System vs. User

Software Components

- To unitize a big software program
- To enable distributed development
- To enable independent / 3rd party developers
- To enable competitive implementations
- To design an architecture

SOFTWARE COMPONENTS IN OPENOFFICE.ORG

Kay Ramme

> kay.ramme@sun.com